

# 60" Curved Glass Deli Case



SD-60

## Features

### **4 Casters (non-locking)**

Also allows for easy moving during cleaning or maintenance.

### **2 Adjustable Glass Shelves**

The glass shelves sit on adjustable mounting brackets to allow for height adjustments shelf by shelf to accommodate different sized products.

### **Interior Lighting**

Lighting provides high visibility for customer's viewing.

### **Anti-Fog Glass Face**

Fully insulated glass face helps with energy savings while providing clear visibility of products inside.

### **Stainless Steel Exterior**

High quality 201 series stainless steel exterior provides both durability and beauty to the unit.

### **Digital Temperature Display**

The LCD display allows for easy visual read out.

Models	Doors	#of Shelves	H/P	AMPS	Gross Weight	W D H
SD-60	2	2	1/2	9.2	568 lbs	59" x 33.5" x 47.25"

# TECHNICAL DATA

## Dimensions

Exterior Dimensions (WxDxH)	59" x 33.5" x 47.25"
Interior Dimensions (WxDxH)	53.25" x 27" x 22"
Cubic Feet	17 cu.ft.
Shelf Depths:	Shelf 1: 12" Shelf 2: 16" Shelf 3: 21"
Gross Weight	568 lbs
Packaging Dimensions (WxDxH)	62.5" x 36.25" x 51"

## Construction

Exterior Material	201 series stainless steel
Interior Material	Glass
Insulation Material	Foamed in place polyurethane
Shelf Load Capacity	44 lbs

## Cooling

Temperature Range	35° - 47° F
Refrigerant	R134a
Maximum Ambient Temperature Rating	100.4° F
Defrosting	Automatic
Temperature Display	Yes
Temperature Controller	Mechanical
H/P	1/2

## Electrical

Voltage	110
Amps	9.2
Hz	60
Phase	1

## PLAN VIEW

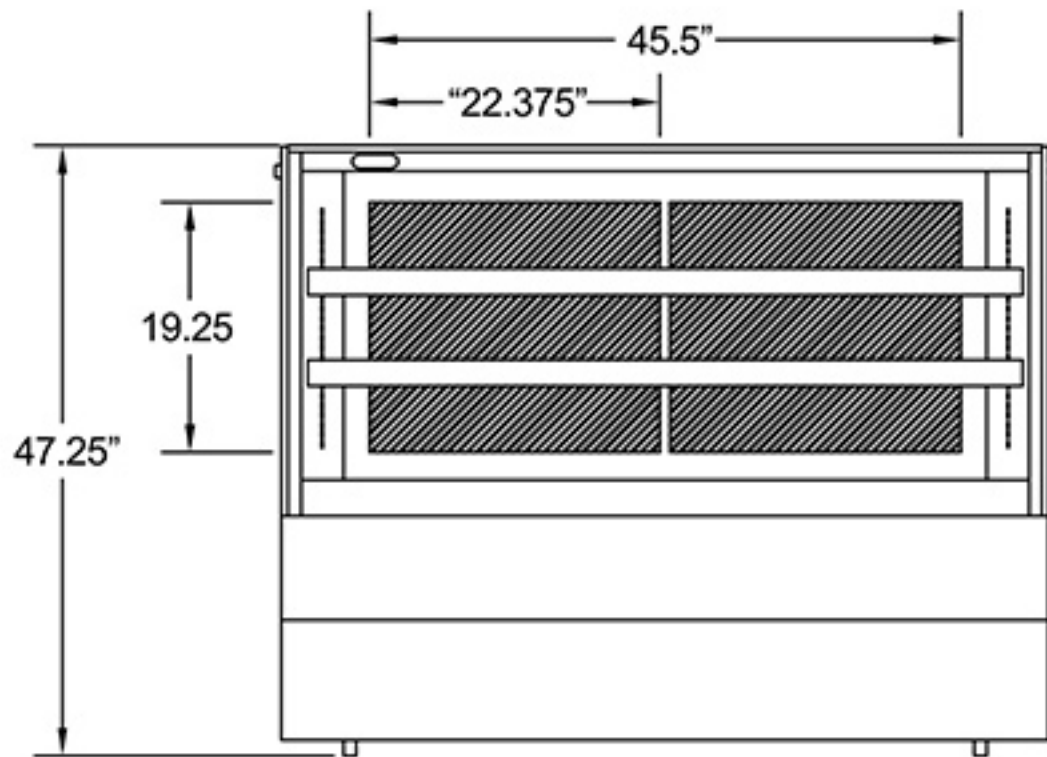

Front View

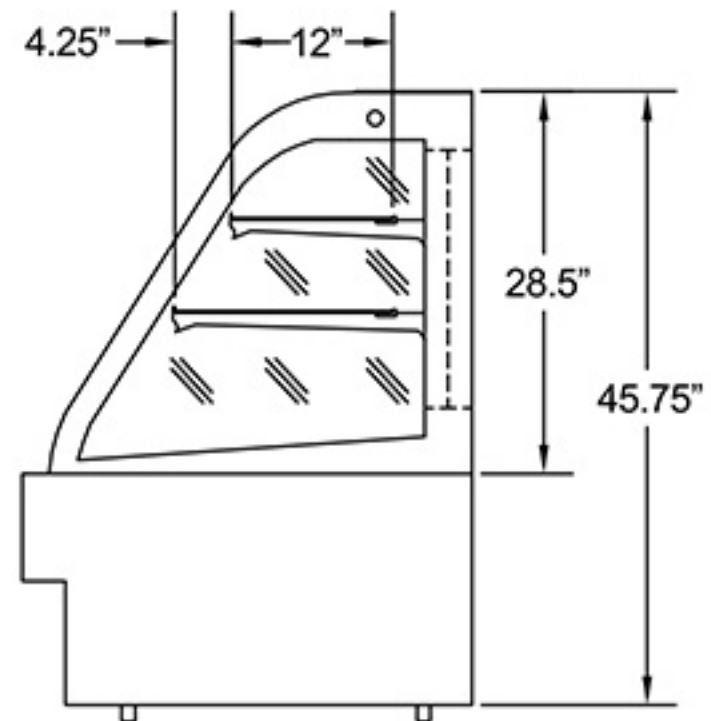

Side View

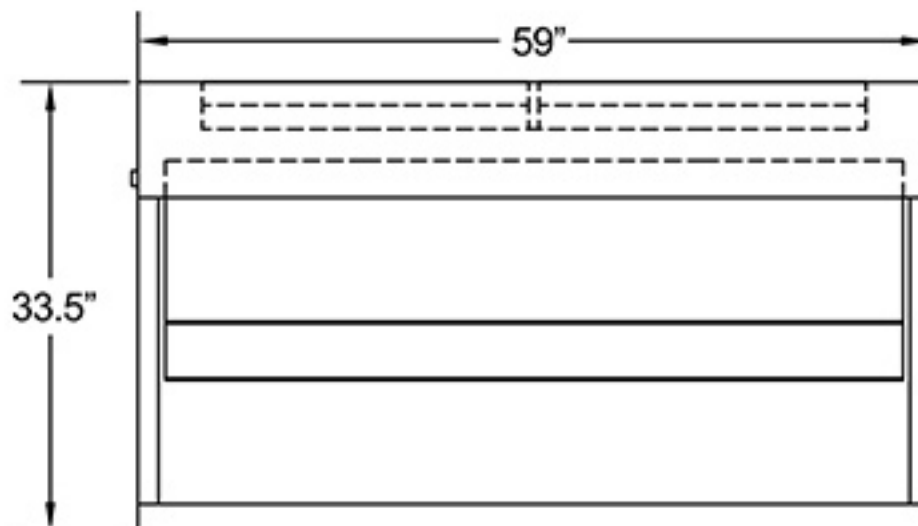

Top View

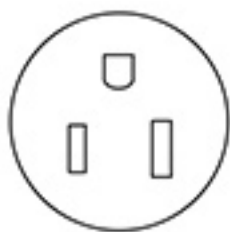

NEMA 5-15