



## 2 Door Under Counter Refrigerator ♦ NP2R-48UC



### Standard Features

- ♦ Stainless steel interior and exterior
- ♦ Rounded corner design for easy cleanup
- ♦ Self closing hinged doors with 90 degree stay open feature
- ♦ Programmable electronic control system
- ♦ Adjustable, heavy duty PVC coated shelves
- ♦ Heavy-duty castor wheels

### Technical Specifications

Product Classification	Refrigerator
Climate Class	N
Power	920W
Number of Doors	2
External Cabinet Material	430 Stainless Steel
Internal Cabinet Material	304 Stainless Steel
Type of Refrigeration Agent	R-134A
Type of Temperature Control	Digital
Temperature Range °C	0°C to 5°C
Temperature Range °F	32°F to 41°F
Voltage / Frequency	115V / 60Hz
Amp	8.0
Compressor HP	1/3+ HP
Type of Insulation	2.5-Inch Polyurethane Foam
Door Handle	Full Length

### Certified Safety Standard

- ♦ ETL Listed
- ♦ ETL Sanitation Listed



### Warranty Information

- ♦ 5 Years Compressor
- ♦ 3 Year Parts & Labor





## 2 Door Under Counter Refrigerator ♦ NP2R-48UC

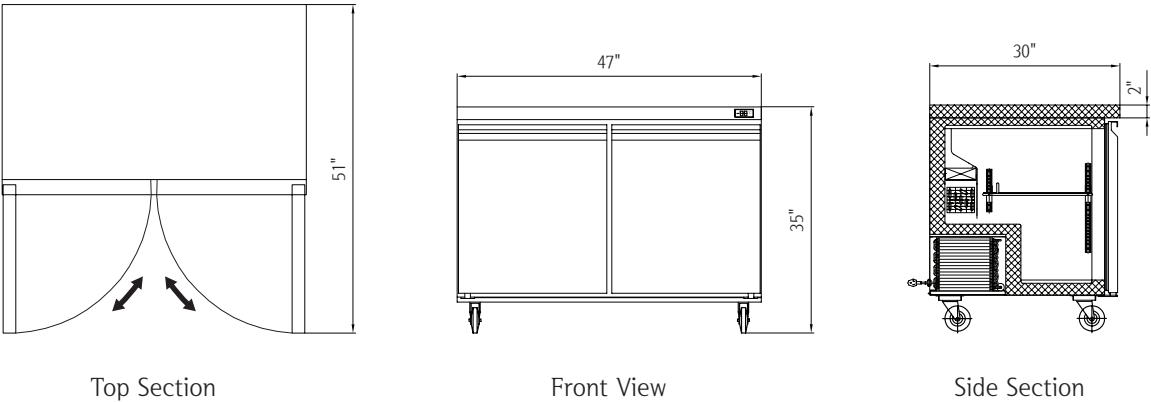

Plug Type: (NEMA) 5-15P

### Capacity

Capacity 12 cu. ft.

### Dimensions

Internal Cabinet Width 43 in  
 Internal Cabinet Depth 23 in  
 Internal Cabinet Height 24 in  
 External Width 47 in  
 External Depth 30 in  
 External Height 35 in  
 Shipping Dimensions (W x D x H) 50 x 32 x 39 in

### Weight

Gross Weight 304 lbs.

### Accessories

Frost Free Yes  
 Adjustable Shelves 2  
 Fixed Shelves No  
 Internal Light No  
 Internal Light Switch No  
 External Light Switch No  
 Self Closing Door / Lid Yes  
 Door Holder for Loading Yes  
 Door / Lid Lock No  
 Reversible (Left) Door No  
 Adjustable Feet Optional  
 Adjustable Thermostat Yes