

# norpole

## 50-Inch Sliding Door Beer Cooler ♦ NPBC-50



### Standard Features

- ♦ Sliding aluminum lids
- ♦ Polyurethane high density cell insulation
- ♦ Removable door gasket
- ♦ Integrated bottle opener with cap catcher
- ♦ Forced-air cooling
- ♦ Epoxy coated evaporator

### Technical Specifications

Product Classification	Refrigerator
Climate Class	N
Power	920W
Number of Doors	2
External Cabinet Material	Wear Resistant Vinyl
Internal Cabinet Material	Epoxy Coated Aluminum
Type of Refrigeration Agent	R-134A
Type of Temperature Control	Digital
Temperature Range °C	0°C to 3.3°C
Temperature Range °F	32°F to 38°F
Voltage / Frequency	115V / 60Hz
Amp	8.0
Compressor HP	1/4+ HP
Type of Insulation	1.6-Inch Polyurethane Foam
Door Handle	Partial Length

### Certified Safety Standard

- ♦ ETL Listed
- ♦ ETL Sanitation Listed



### Warranty Information

- ♦ 5 Years Compressor
- ♦ 3 Year Parts & Labor





# 50-Inch Sliding Door Beer Cooler ♦ NPBC-50

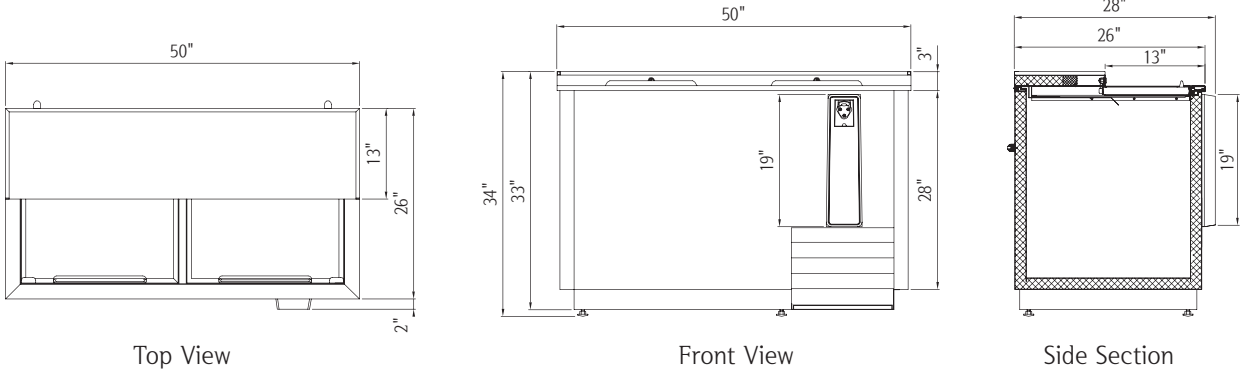

Plug Type: (NEMA) 5-15P

### Capacity

Gross Capacity	16 cu. ft.
Storage Capacity	24 Cases (12 oz. Cans)

### Dimensions

Internal Cabinet Width	45 in
Internal Cabinet Depth	26 in
Internal Cabinet Height	23 in
External Width	50 in
External Depth	28 in
External Height	34 in
Shipping Dimensions (W x D x H)	56 x 33 x 42 in

### Weight

Gross Weight	296 lbs.
--------------	----------

### Accessories

Castor Wheels	Optional
Frost Free	Yes
Epoxy Coated Divider	Yes
Adjustable Thermostat	Yes